

**CARATTERISTICHE • SPECIFICATIONS • CARACTERISTIQUES
ANGABEN • CARACTERISTICAS • ХАРАКТЕРИСТИКИ**

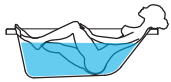

~ 305 l



~ 265 l



220-240 V - 50/60 Hz
6/ 12 (*) A
1,2 / 2,5 (*) kW



200x108x74 cm
~ 125 kg



~ 75 kg



~ 220 kg/m²

**SHARP
DOUBLE
190X90**

(*) con sistema di mantenimento della temperatura dell'acqua • with water temperature control system • avec système de maintien de la température de l'eau
mit system zur Erhaltung der Wassertemperatur • con sistema de mantenimiento de la temperatura del agua • с система поддержания температуры воды

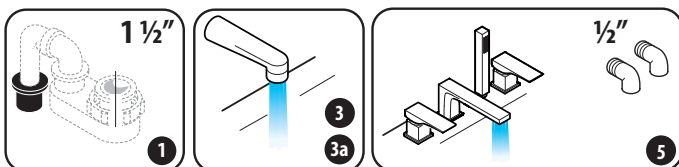
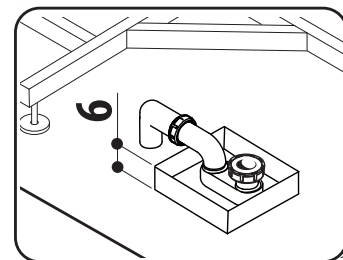
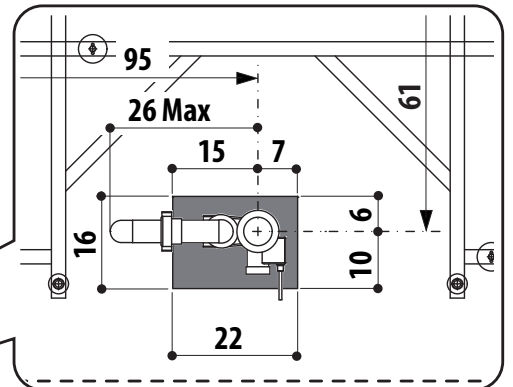
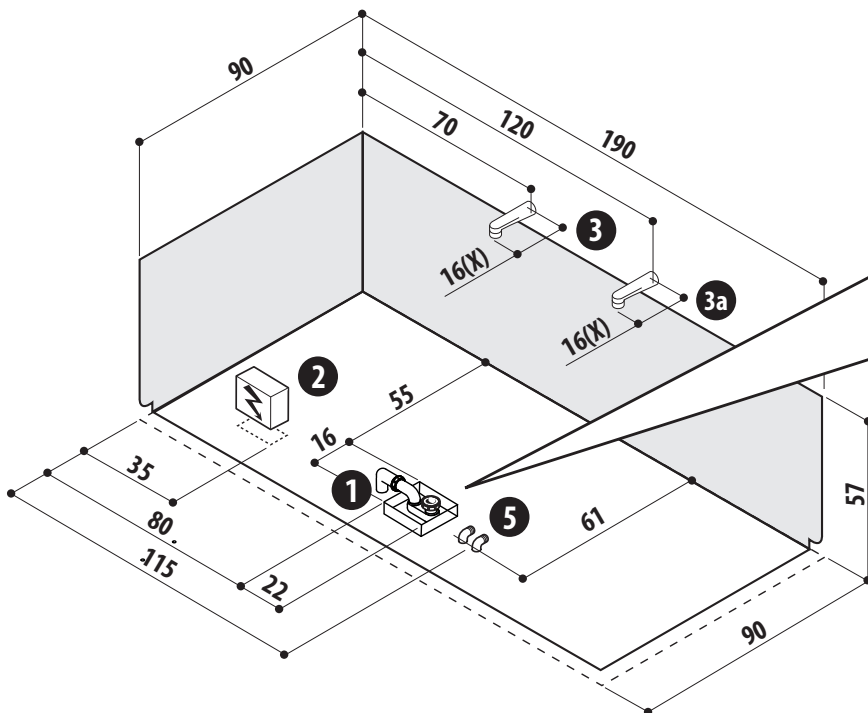
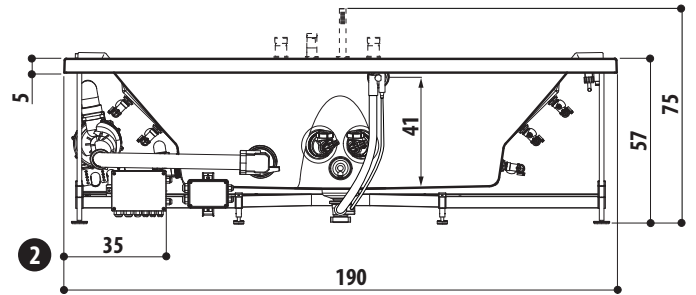
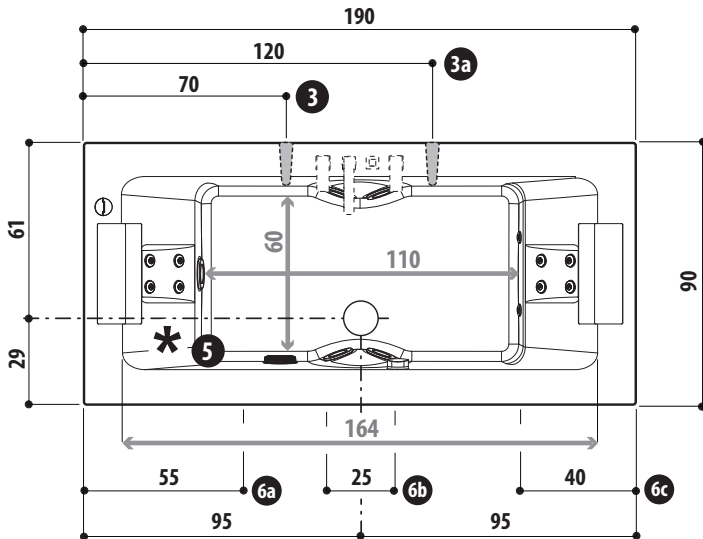

cm



I disegni riportati non sono in scala / The show drawings are not scaled / Les dessins reportés ne sont pas à l'échelle
Die Zeichnungen sind nicht im Maßstab / Los dibujos representados no son en escala / Рисунки приведены не в масштабе

ALLEGARE IL TESTO DI PREINSTALLAZIONE - ADD TO THIS SHEET THE PREINSTALLATION INSTRUCTIONS - FICHE À ASSOCIER AU TEXT DE PRE-INSTALLATION - DIESES DATENBLATT MUSS VOM VORINSTALLATIONS TEXT - FICHA A UNIRSE AL TEXTO DE PREINSTALACIÓN - ПРИЛОЖИТЬ К ПРЕДВАРИТЕЛЬНОЙ ТЕКСТАМ