

**CARATTERISTICHE • SPECIFICATIONS • CARACTERISTIQUES  
ANGABEN • CARACTERISTICAS • ХАРАКТЕРИСТИКИ**

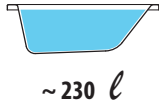

~ 230 l

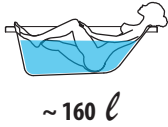

~ 160 l



220-240 V - 50/60 Hz  
6/12 (\*) A  
1,2 / 2,5 (\*) kW



180x80x74 cm  
~ 85 kg



~ 60 kg

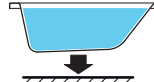

~ 245 kg/m<sup>2</sup>

**SHARP 70  
170X70**

(\*) con sistema di mantenimento della temperatura dell'acqua • with water temperature control system • avec système de maintien de la température de l'eau  
mit system zur Erhaltung der Wassertemperatur • con sistema de mantenimiento de la temperatura del agua • с система поддержания температуры воды

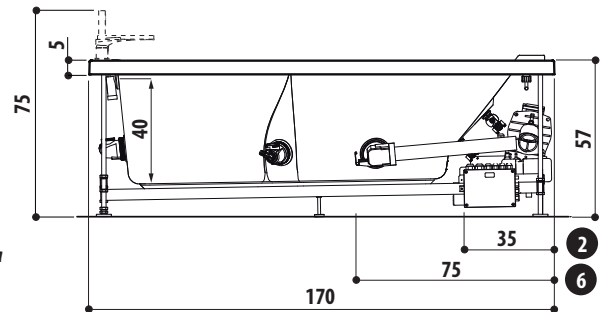
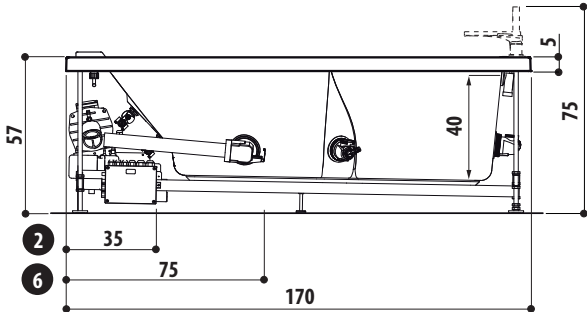

*I disegni riportati non sono in scala  
The show drawings are not scaled  
Les dessins reportés ne  
sont pas à l'échelle  
Die Zeichnungen sind  
nicht im Maßstab  
Los dibujos representa-  
dos no son en escala  
Рисунки приведены  
не в масштабе*

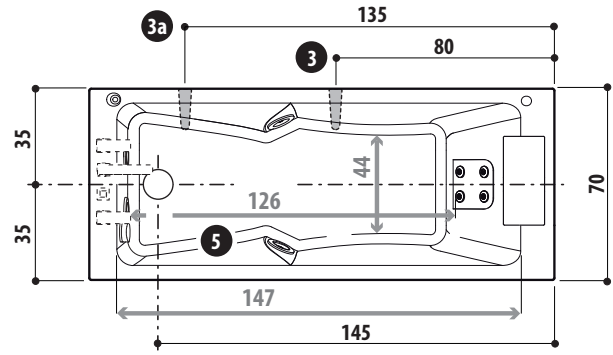
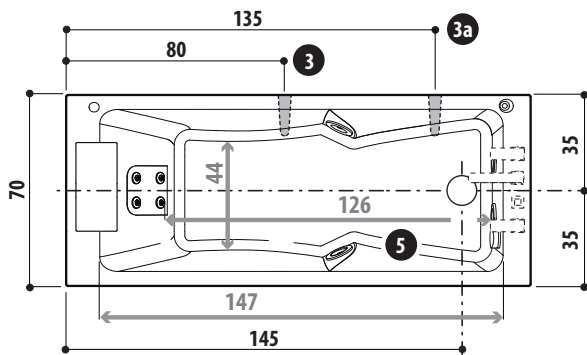

SX

cm

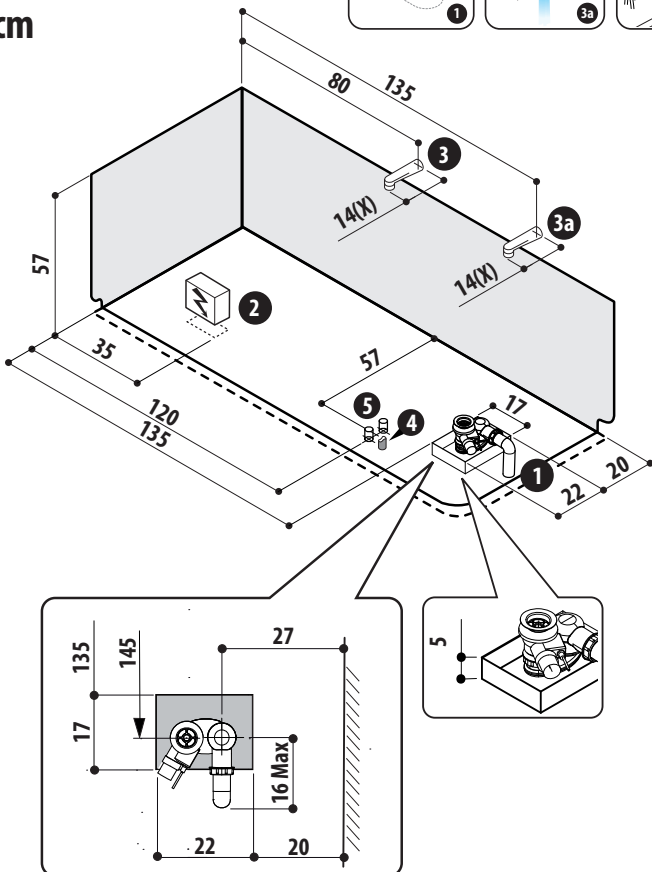
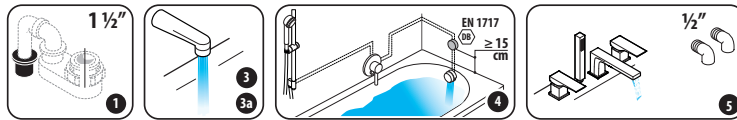

DX

cm

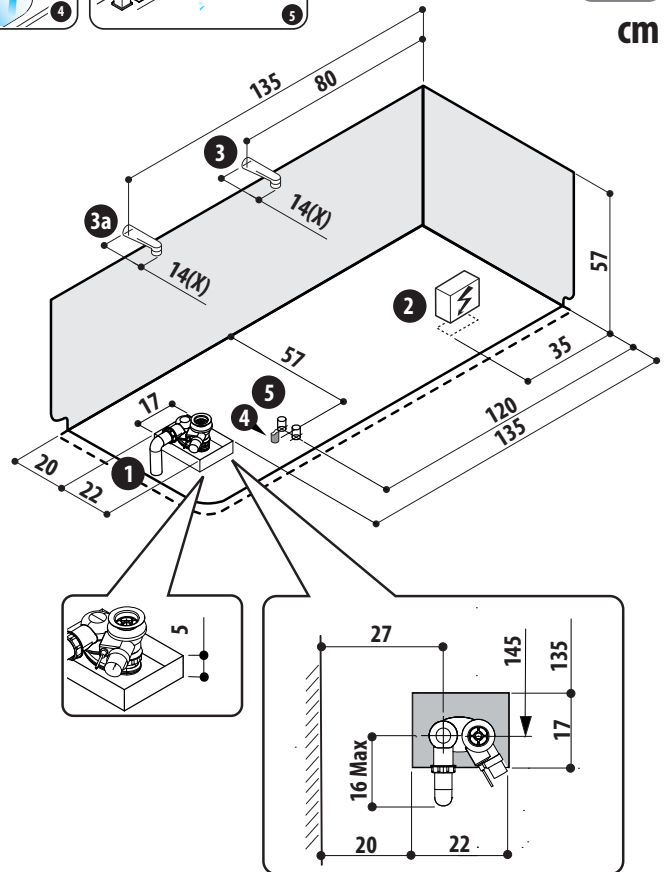

ALLEGARE IL TESTO DI PREINSTALLAZIONE - ADD TO THIS SHEET THE PREINSTALLATION INSTRUCTIONS - FICHE À ASSOCIER AU TEXT DE PRE-INSTALLATION - DIESES DATENBLATT MUSS VOM VORINSTALLATIONS TEXT - FICHA A UNIRSE AL TEXTO DE PREINSTALACIÓN  
ПРИЛОЖИТЬ К ПРЕВАРИТЕЛЬНОЙ ТЕКСТАМ

**CARATTERISTICHE • SPECIFICATIONS • CARACTERISTIQUES  
ANGABEN • CARACTERISTICAS • ХАРАКТЕРИСТИКИ**



220-240 V - 50/60 Hz  
6/12 (²) A  
1,2/ 2,5 (²) kW

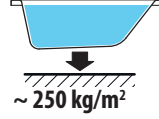
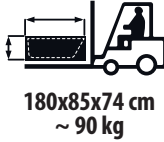

**SHARP 75  
170X75**

(\*) con sistema di mantenimento della temperatura dell'acqua - with water temperature control system - avec système de maintien de la température de l'eau  
mit system zur Erhaltung der Wassertemperatur - con sistema de mantenimiento de la temperatura del agua - с система поддержания температуры воды

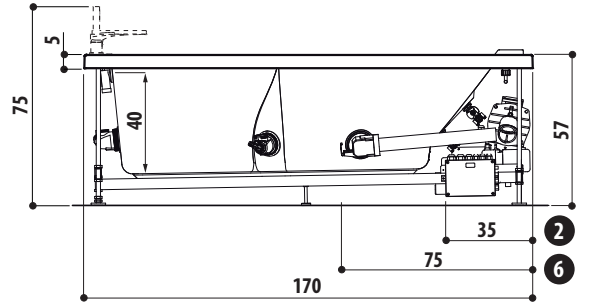
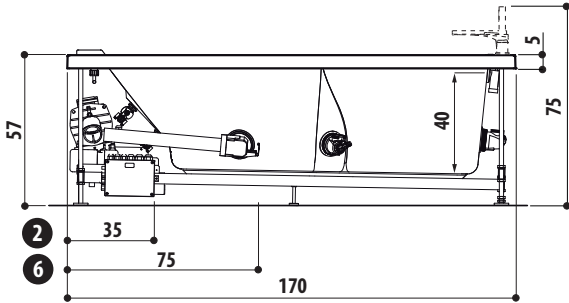

*I disegni riportati non sono in scala  
The show drawings are not scaled  
Les dessins reportés ne  
sont pas à l'échelle  
Die Zeichnungen sind  
nicht im Maßstab  
Los dibujos representa-  
dos no son en escala  
Рисунки приведены  
не в масштабе*

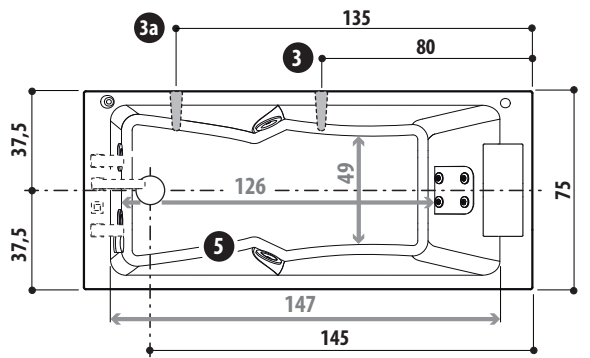
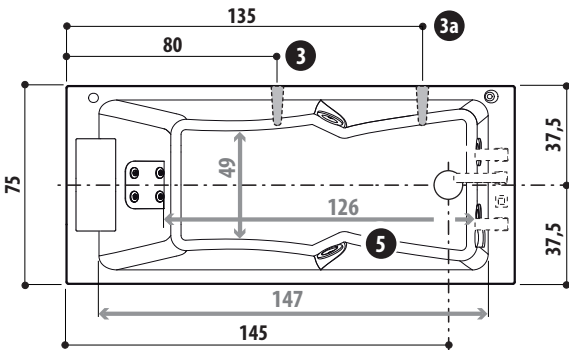

**SX**  
cm

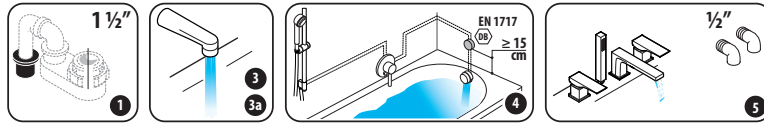

**DX**  
cm

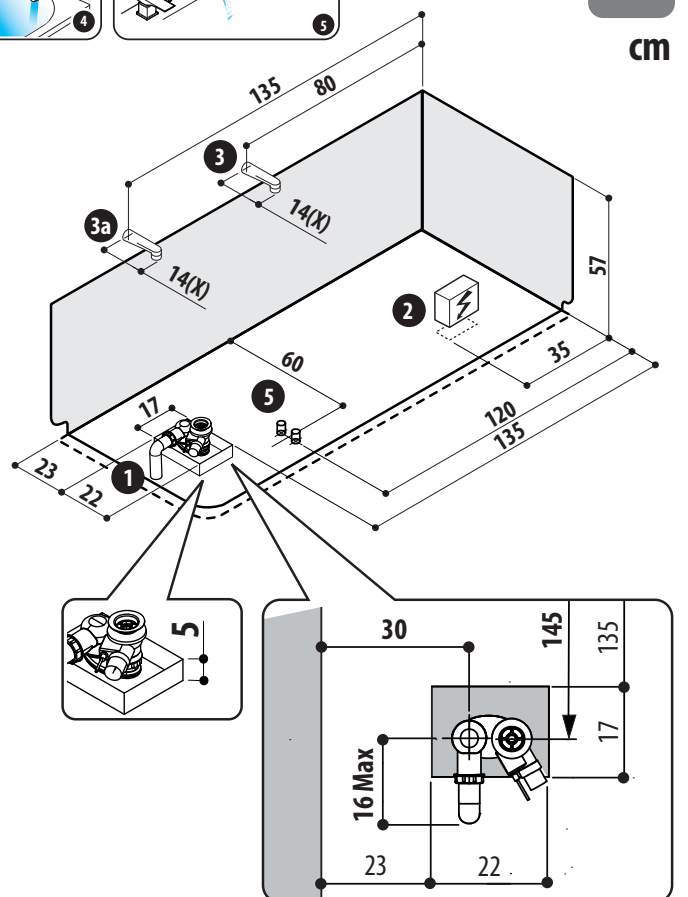
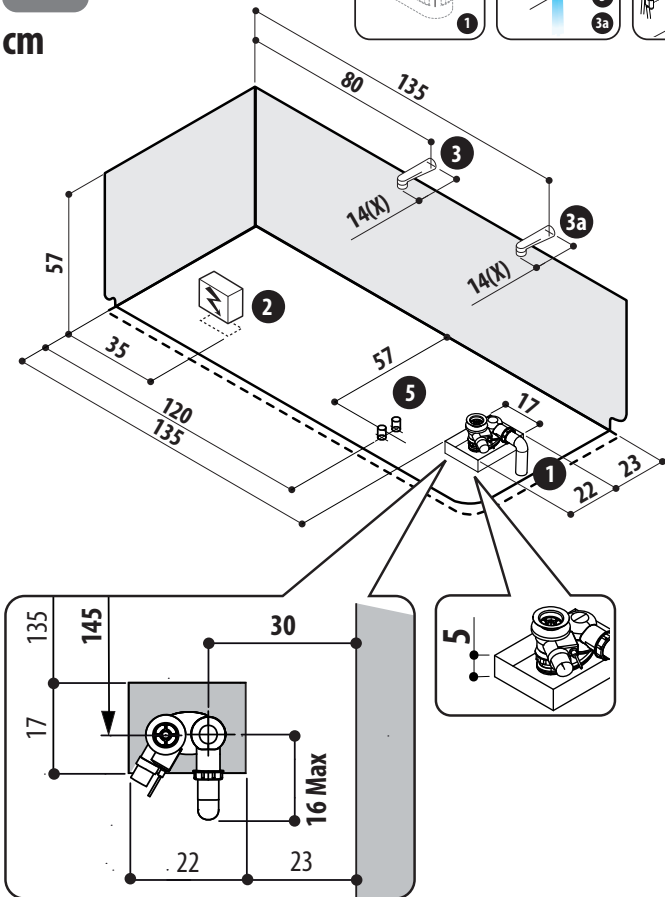

ALLEGARE IL TESTO DI PREINSTALLAZIONE - ADD TO THIS SHEET THE PREINSTALLATION INSTRUCTIONS - FICHE À ASSOCIER AU TEXT DE PRE-INSTALLATION - DIESES DATENBLATT MUSS VOM VORINSTALLATIONS TEXT - FICHA A UNIRSE AL TEXTO DE PREINSTALACIÓN  
ПРИЛОЖИТЬ К ПРЕВАРИТЕЛЬНОЙ ТЕКСТАМ 1